

Swing clamps pneumatic, Form A

Item description/product images

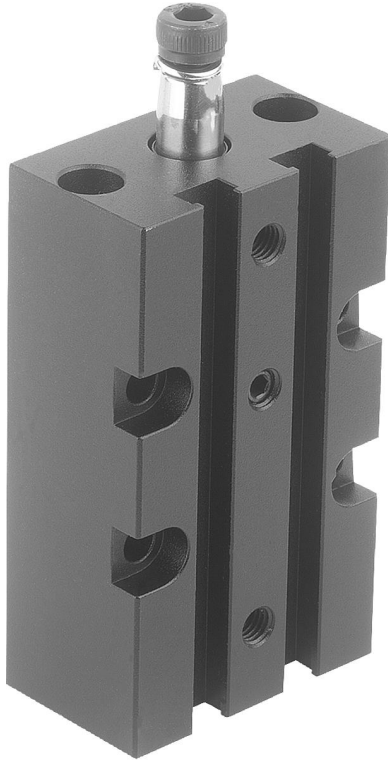

Description

Material:

Body aluminium.

Double-acting piston rod stainless steel.

Version:

Body black anodised.

Note:

Swing clamps are used where low clamping forces suffice or where the clamping point must be free when mounting and removing the workpiece. The block form of the housing offers universal fastening possibilities. The magnetic piston is primed for electrical end position feedback.

Including screw and lock washer for fastening the clamping arms (accessories).

The swing action of the clamp should not be blocked.

F1 = at 6 bar (max. operating pressure).

On request:

Proximity switch.

Accessory:

- Clamping arm K1816
- Adapter K1817

Examples:

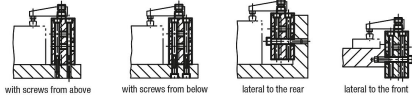

with screws from above

with screws from below

lateral to the rear

lateral to the front

Swing clamps pneumatic, Form A

Drawings

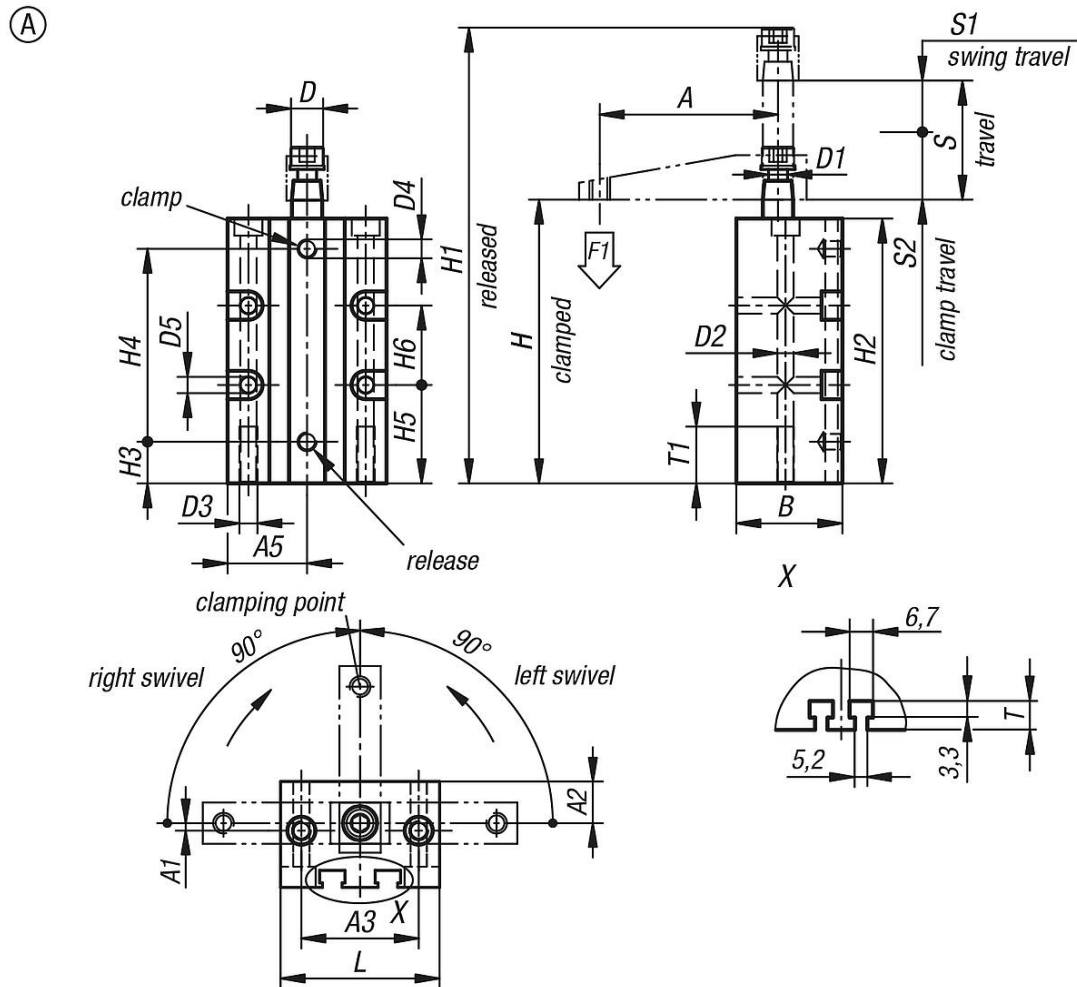

Overview of items

| Order No. | Version 2 | Form | Size | A | A1 | A2 | A3 | A5 | B | D | D1 | D2 | D3 | D4 | D5 |
|------------|---------------------|------|------|----|----|----|----|----|----|---|----|-----|----|----|-----|
| K1815.1121 | swivel to the right | A | 12 | 35 | 0 | 10 | 31 | 20 | 24 | 8 | M5 | 4,3 | M5 | M5 | 4,3 |
| K1815.1161 | swivel to the right | A | 16 | 41 | -2 | 11 | 31 | 21 | 28 | 8 | M5 | 4,3 | M5 | M5 | 4,3 |
| K1815.2121 | swivel to the left | A | 12 | 35 | 0 | 10 | 31 | 20 | 24 | 8 | M5 | 4,3 | M5 | M5 | 4,3 |
| K1815.2161 | swivel to the left | A | 16 | 41 | -2 | 11 | 31 | 21 | 28 | 8 | M5 | 4,3 | M5 | M5 | 4,3 |

| Order No. | H | H1 | H2 | H3 | H4 | H5 | H6 | Travel S | L | S1 | S2 | T | T1 | F1 N |
|------------|----|-----|----|----|----|----|----|----------|----|----|----|-----|----|------|
| K1815.1121 | 76 | 105 | 70 | 11 | 51 | 26 | 21 | 16 | 40 | 7 | 9 | 5 | 15 | 30 |
| K1815.1161 | 76 | 105 | 70 | 11 | 51 | 26 | 21 | 16 | 42 | 7 | 9 | 4,5 | 15 | 60 |
| K1815.2121 | 76 | 105 | 70 | 11 | 51 | 26 | 21 | 16 | 40 | 7 | 9 | 5 | 15 | 30 |
| K1815.2161 | 76 | 105 | 70 | 11 | 51 | 26 | 21 | 16 | 42 | 7 | 9 | 4,5 | 15 | 60 |