

Thrust pads DIN 6311 enhanced

Item description/product images

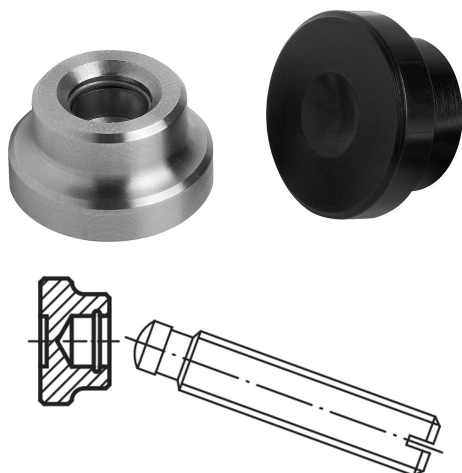

Description

Material:

Steel: case-hardened. Snap ring spring steel.

Stainless steel: bright. Snap ring stainless steel.

Version:

Steel black oxidised.

Stainless steel bright.

Note:

To press onto a thrust point, incline the point as far as possible over the snap ring opening and twist in. The snap ring is supplied assembled.

Drawing reference:

Form S: standard thrust pad

Form T: low version, large thrust face

1) thrust face

Drawings

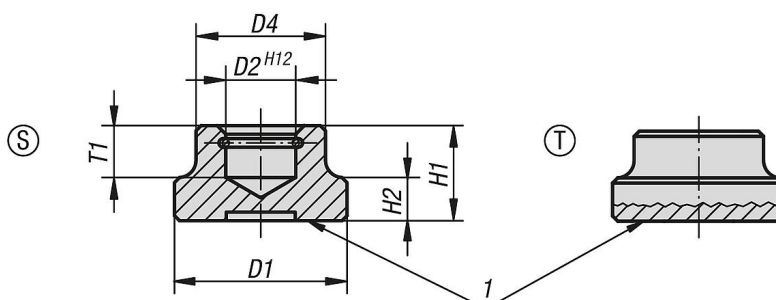

Overview of items

Thrust pads DIN 6311 enhanced

Order No.	Main material	Form	D1	D2	D4	H1	H2	T1	For grub screws with thrust point DIN 6332
K0392.06	steel	S	12	4,6	10	7	2,5	4	M6
K0392.08	steel	S	16	6,1	12	9	4	5	M8
K0392.10	steel	S	20	8,1	15	11	5	6	M10
K0392.12	steel	S	25	8,1	18	13	7	7	M12
K0392.16	steel	S	32	12,1	22	15	7	7,5	M16
K0392.20	steel	S	40	15,6	28	16	9	8	M20
K0392.108	steel	T	25	6,1	12	8	4	4,5	M8
K0392.110	steel	T	32	8,1	18	10	6	6	M10 / M12
K0392.116	steel	T	40	12,1	22	12	7	7	M16
K0392.061	stainless steel	S	12	4,6	10	7	2,5	4	M6
K0392.081	stainless steel	S	16	6,1	12	9	4	5	M8
K0392.101	stainless steel	S	20	8,1	15	11	5	6	M10
K0392.121	stainless steel	S	25	8,1	18	13	7	7	M12
K0392.161	stainless steel	S	32	12,1	22	15	7	7,5	M16
K0392.201	stainless steel	S	40	15,6	28	16	9	8	M20

