

## Power clamp

### Item description/product images

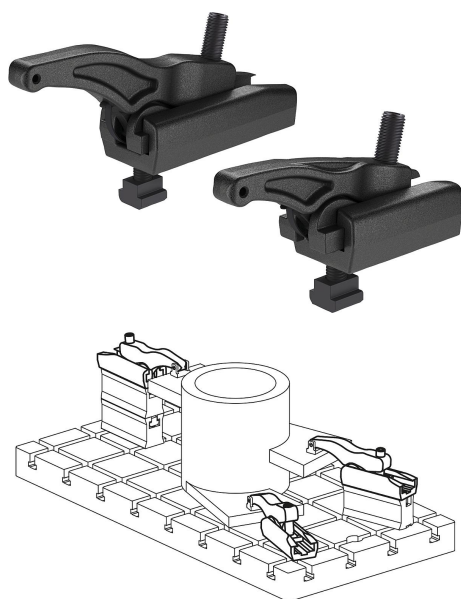

### Description

**Material:**

Carbon steel.

**Version:**

Forged, black electro zinc-plated.

**Note:**

We recommend the use of screw paste to reduce wear on the adjusting screw. The height of the power clamp can also be increased with the riser. A riser is not supplied with the 44 kN and 60 kN power clamps.

Supplied with clamping element, support element, DIN 508 slot key and grade 12.9 bolt.

**Application:**

The height of the clamping arm can be infinitely adjusted using the adjustment screw and the workpiece can then be clamped.

**Advantages:**

- Very high clamping forces 22-60 kN
- Low construction height.
- Simple assembly of the elements.
- Enables quick and uncomplicated clamping.
- Height and length infinitely adjustable.
- Use in 12-28 mm T-slots or M10, M12, M16, M18, M20, M24 grid systems.
- Thrust pad available in smooth and serrated versions.

**Accessory:**

Riser K1206.

Thrust pad stainless steel K1215.

Thrust pad plastic K2226.

### Drawings

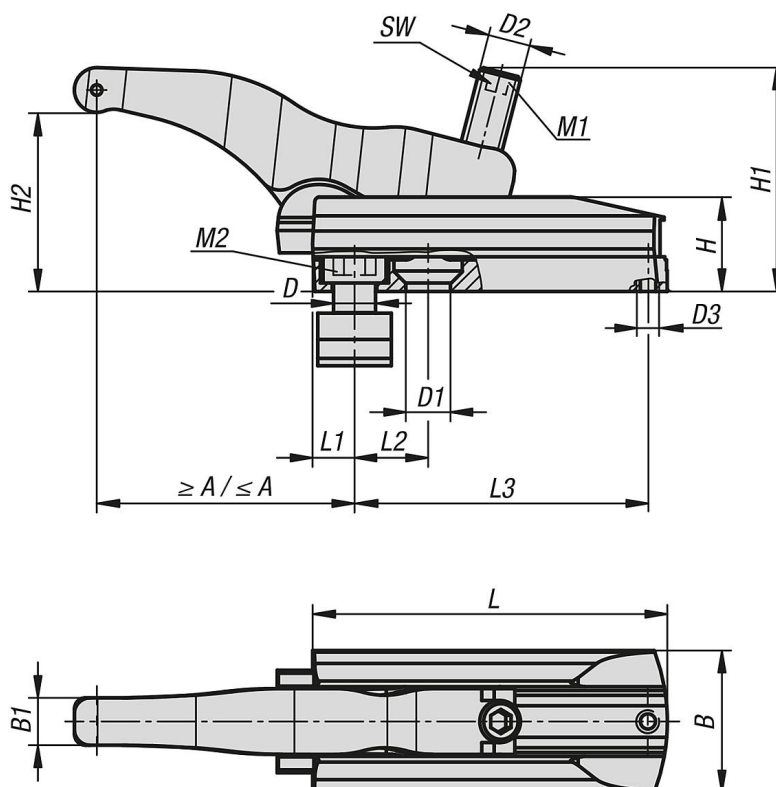

### Overview of items

#### Power clamp

Order No.	Version 1	H2	A min.	A max.	B	B1	Slot width	D	D1	D2	D3	H	H1	L	L1	L2	L3	SW	Clamping force kN	Tightening torque M1 Nm	Tightening torque M2 Nm
K1205.112135	long	6-68	13	110	54	18	14	M12	13	M16	M8	36	85	135	13	25	115	8	30	100	70
K1205.116135	long	6-68	16	114	54	18	18	M16	17	M16	M8	36	85	135	16	28	115	8	30	100	150
K1205.116155	long	5-80	16	134	60	20	18	M16	17	M20	M8	42	105	155	16	32	131	10	43	220	150
K1205.120175	long	7-88	19	165	75	25	22	M20	21	M24	M10	52	125	175	19	36	146,5	12	49	220	200
K1205.210065	short	5-38	15	50	45	13	12	M10	-	M12	M6	30	58	65	11	-	47,5	6	22	50	35
K1205.212065	short	5-38	15	50	45	13	14	M12	-	M12	M6	30	58	65	11	-	47,5	6	22	50	40
K1205.212095	short	6-50	12	82	54	18	14	M12	13	M16	M8	36	78	95	12	20	76	8	32	120	70
K1205.216110	short	6-50	15	95	60	20	18	M16	17	M20	M8	42	92	110	15	26	87	10	40	150	150
K1205.118176	long	7-88	36	165	75	25	20	M18	21	M24	M10	52	125	176	20	36	146,5	12	44	180	160
K1205.124203	long	8-102	63	180	90	30	28	M24	24,5	M24	M10	57	143	203	23	45	164,5	12	60	300	280