

Technical Informations

Workpiece positioning

Clamping by means of pull clamp and clamping pin

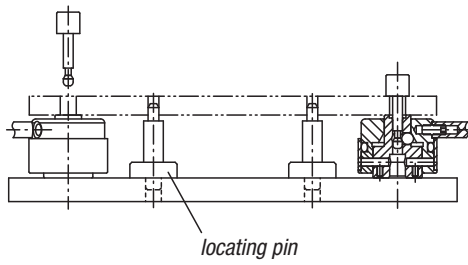

Simultaneous clamping and positioning of a workpiece

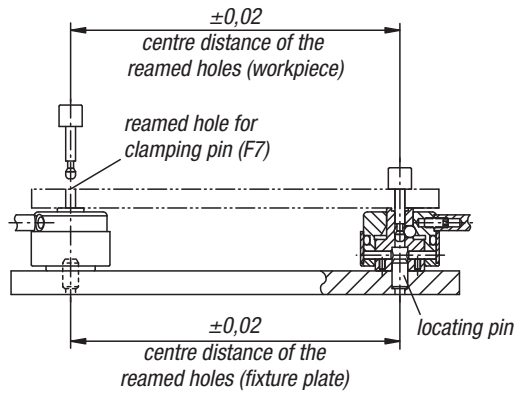

Holding forces for workpiece processing

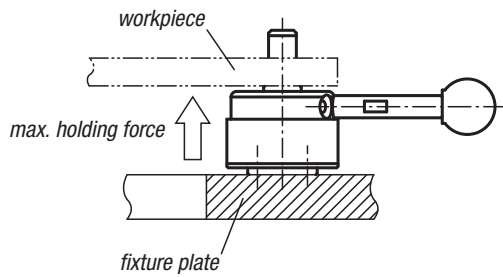

Make sure that no force exceeding the values in the table is affecting the bottom of the workpiece.

