

Assembly and installation instructions for precision indexing plungers

**Precision indexing plungers
with tapered indexing pin**

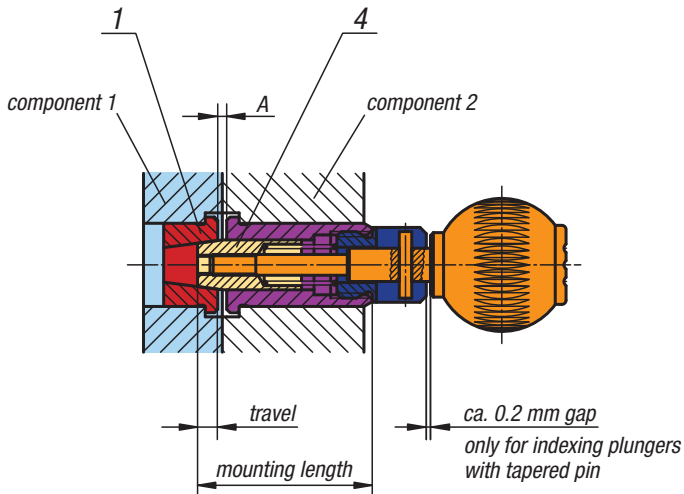

**Precision indexing plungers
with cylindrical indexing pin**

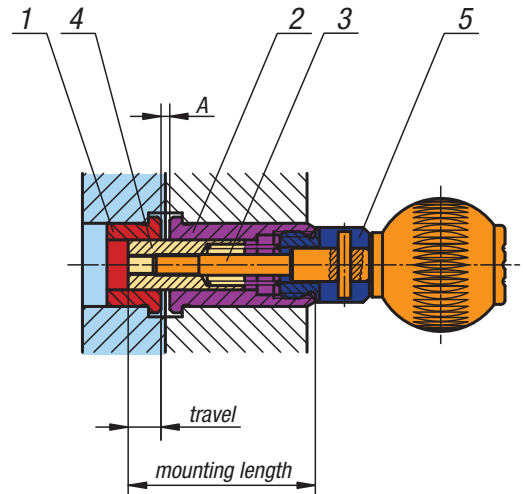

Assembly instructions:

1. Fit tapered or cylindrical bush (No. 1) into component 1.
2. Mount sleeve (No. 2) into component 2.
3. Determine mounting length (actual dimension). Mounting length = A + stroke + length pos. 2. Models with tapered pin should have a 0.2 mm gap.
4. Glue screw (No. 3) and centering pin (No. 4) together grease-free with anaerobic adhesive. We recommend Loctite 638.
5. Screw centering pin with nut (No. 4) and handle into the mounted sleeve (No. 2). If necessary glue together grease-free with anaerobic adhesive.
6. Check whether the product is operational. Adhere to the index stroke length given in the catalogue.

Note:

The precision indexing plunger is only ready for operation after the stated adhesive hardening time. When gluing the components, ensure that no adhesive enters into contact with movable parts.

