

Technical information for stationary chucks

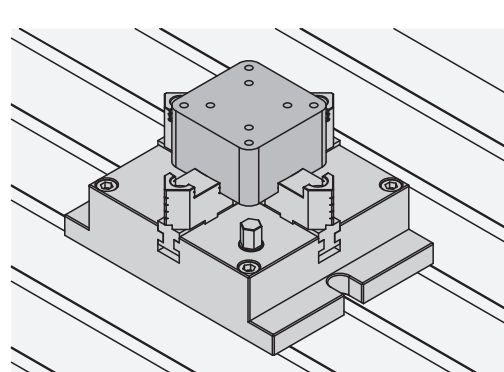

Function

Stationary 3 and 4-jaw chucks are especially suitable for centric workpiece holding on drilling and milling machines. The flexible arrangement of the hard and soft jaws enable diverse sizes and shapes of workpieces to be easily held on the outside or inside faces.

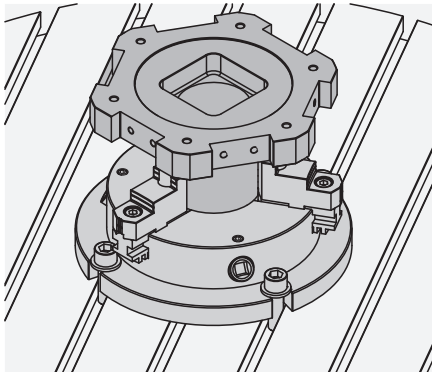
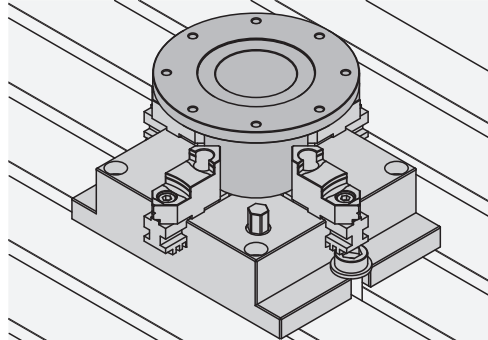
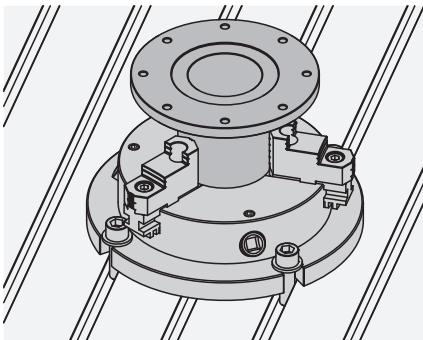
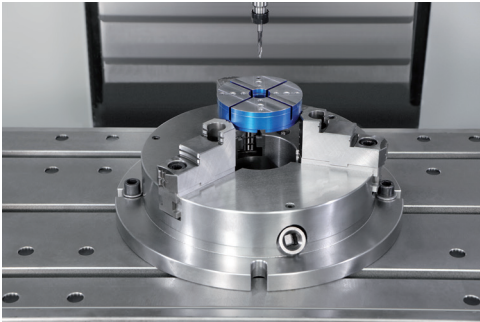

Precision:

1. The chucks are precision ground. The W, X, Y, Z tolerances between the chucks is within 0.05 mm.

2. The repeat accuracy by centric clamping with hard jaws is within 0.02 mm.

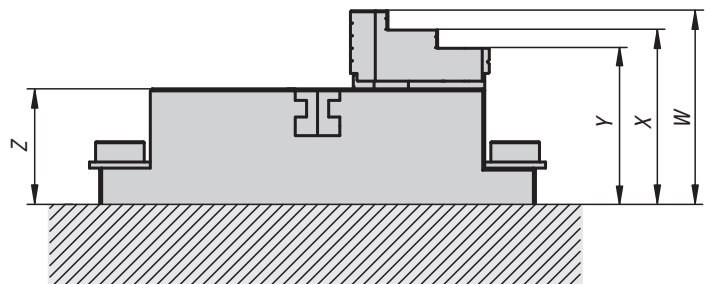

Technical information for stationary chucks



Actuation:

The moveable jaw bases are driven by the internal scroll plate.

The rotation of the pinion transfers the force over the scroll plate to the jaw bases and generates a synchronous movement of the jaws inwards or outwards.

Chuck advantages.

1. Body precision ground
2. Flat design
3. Optimum accessibility to the lubrication system
4. Wide chuck bore for holding bar material
5. Actuated using a hex key. Quick and easy operation.
6. Soft jaws can also be attached to the jaw bases.

Note:

Inadequate lubrication leads to excessive wear and reduction of the clamping force. Please ensure regular lubrication intervals.

Stationary 3-jaw chuck

Torque and clamping force specifications for the jaws.

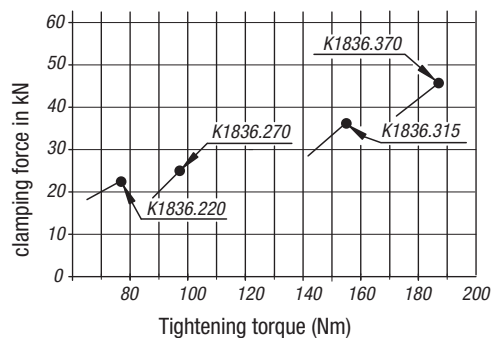

Stationary 4-jaw chuck

