

Lateral spring plungers

Item description/product images



Description

Material:

Sleeve aluminium.
Spring steel.
Thrust pin steel or POM.

Version:

Steel thrust pin hardened and electro zinc-plated.
Sleeve blue electro zinc-plated.

Note:

Lateral spring plungers are for positioning, clamping, holding and securing workpieces and parts for engraving, labelling, drilling, reaming, tapping, honing, grinding, welding, soldering, assembling, mounting etc.
Suitable eccentric adjustment bush see K0369.
W and Z are customer specified.

Drawing reference:

1) assembly tool

Drawings

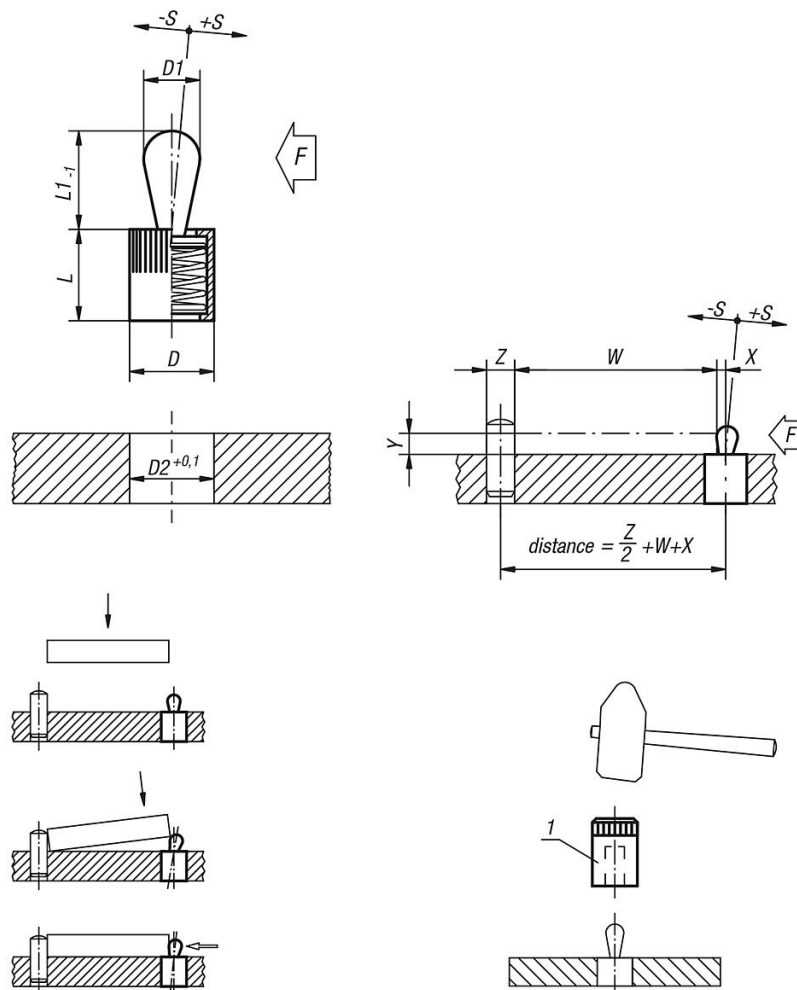

Lateral spring plungers

Overview of items

Lateral spring plungers

Order No.	Version 1	Material	D	D1	L	L1	D2	±S	F approx. N	X if Y = 1	X if Y = 2	X if Y = 3	X if Y = 4.5	X if Y = 6	X if Y = 8	Order No. assembly tool
K0368.21034	without seal	steel	6	3	7	4	6	0,5	10	0,8	1	1	1	1	1	K0369.03
K0368.21036	without seal	steel	6	3	7	4	6	0,5	20	0,8	1	1	1	1	1	K0369.03
K0368.21038	without seal	steel	6	3	7	4	6	0,5	40	0,8	1	1	1	1	1	K0369.03
K0368.21054	without seal	steel	10	5	11	6,7	10	0,8	20	-	1,5	1,7	1,7	1,7	1,7	K0369.05
K0368.21056	without seal	steel	10	5	11	6,7	10	0,8	50	-	1,5	1,7	1,7	1,7	1,7	K0369.05
K0368.21058	without seal	steel	10	5	11	6,7	10	0,8	100	-	1,5	1,7	1,7	1,7	1,7	K0369.05
K0368.21064	without seal	steel	10	6	11	10,7	10	1	40	-	-	-	1,7	1,9	1,9	K0369.05
K0368.21066	without seal	steel	10	6	11	10,7	10	1	75	-	-	-	1,7	1,9	1,9	K0369.05
K0368.21068	without seal	steel	10	6	11	10,7	10	1	100	-	-	-	1,7	1,9	1,9	K0369.05
K0368.21084	without seal	steel	12	8	13	13,9	12	1,3	50	-	-	-	-	2,5	2,7	K0369.08
K0368.21086	without seal	steel	12	8	13	13,9	12	1,3	100	-	-	-	-	2,5	2,7	K0369.08
K0368.21088	without seal	steel	12	8	13	13,9	12	1,3	150	-	-	-	-	2,5	2,7	K0369.08
K0368.21104	without seal	steel	16	10	17	16,7	16	1,6	100	-	-	-	-	-	3,1	K0369.10
K0368.21106	without seal	steel	16	10	17	16,7	16	1,6	150	-	-	-	-	-	3,1	K0369.10
K0368.21108	without seal	steel	16	10	17	16,7	16	1,6	200	-	-	-	-	-	3,1	K0369.10
K0368.22034	with seal	steel	6	3	7	4	6	0,5	10	0,8	1	1	1	1	1	K0369.03
K0368.22036	with seal	steel	6	3	7	4	6	0,5	20	0,8	1	1	1	1	1	K0369.03
K0368.22038	with seal	steel	6	3	7	4	6	0,5	40	0,8	1	1	1	1	1	K0369.03
K0368.22054	with seal	steel	10	5	12	6	10	0,8	20	-	1,5	1,7	1,7	1,7	1,7	K0369.05
K0368.22056	with seal	steel	10	5	12	6	10	0,8	50	-	1,5	1,7	1,7	1,7	1,7	K0369.05
K0368.22058	with seal	steel	10	5	12	6	10	0,8	100	-	1,5	1,7	1,7	1,7	1,7	K0369.05
K0368.22064	with seal	steel	10	6	12	10	10	1	40	-	-	-	1,7	1,9	1,9	K0369.05
K0368.22066	with seal	steel	10	6	12	10	10	1	75	-	-	-	1,7	1,9	1,9	K0369.05
K0368.22068	with seal	steel	10	6	12	10	10	1	100	-	-	-	1,7	1,9	1,9	K0369.05
K0368.22084	with seal	steel	12	8	14	13	12	1,3	50	-	-	-	-	2,5	2,7	K0369.08
K0368.22086	with seal	steel	12	8	14	13	12	1,3	100	-	-	-	-	2,5	2,7	K0369.08
K0368.22088	with seal	steel	12	8	14	13	12	1,3	150	-	-	-	-	2,5	2,7	K0369.08
K0368.22104	with seal	steel	16	10	18	16	16	1,6	100	-	-	-	-	-	3,1	K0369.10
K0368.22106	with seal	steel	16	10	18	16	16	1,6	150	-	-	-	-	-	3,1	K0369.10
K0368.22108	with seal	steel	16	10	18	16	16	1,6	200	-	-	-	-	-	3,1	K0369.10
K0368.71034	without seal	polyacetal	6	3	7	4	6	0,5	10	0,8	1	1	1	1	1	K0369.03
K0368.71054	without seal	polyacetal	10	5	11	6,7	10	0,8	20	-	1,5	1,7	1,7	1,7	1,7	K0369.05
K0368.71064	without seal	polyacetal	10	6	11	10,7	10	1	40	-	-	-	1,7	1,9	1,9	K0369.05
K0368.71084	without seal	polyacetal	12	8	13	13,9	12	1,3	50	-	-	-	-	2,5	2,7	K0369.08
K0368.71104	without seal	polyacetal	16	10	17	16,7	16	1,6	100	-	-	-	-	-	3,1	K0369.10
K0368.72034	with seal	polyacetal	6	3	7	4	6	0,5	10	0,8	1	1	1	1	1	K0369.03
K0368.72054	with seal	polyacetal	10	5	12	6	10	0,8	20	-	1,5	1,7	1,7	1,7	1,7	K0369.05
K0368.72064	with seal	polyacetal	10	6	12	10	10	1	40	-	-	-	1,7	1,9	1,9	K0369.05
K0368.72084	with seal	polyacetal	12	8	14	13	12	1,3	50	-	-	-	-	2,5	2,7	K0369.08
K0368.72104	with seal	polyacetal	16	10	18	16	16	1,6	100	-	-	-	-	-	3,1	K0369.10