

Technical information for ball lock pins K2258 and locating bushes K2259

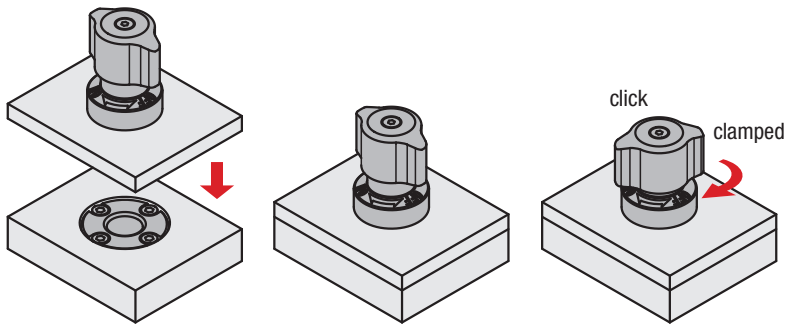

1. Application:



Ensure that the twist knob is in the „OFF“ position.

Set the ball lock pin in the premounted clamping plate. Turn the twist knob to the „ON“ position. When fully clamped, an audible click will be heard.

2. Function:

The tapered pin presses the balls against the tapered surface of the locating bush and clamps the two plates.

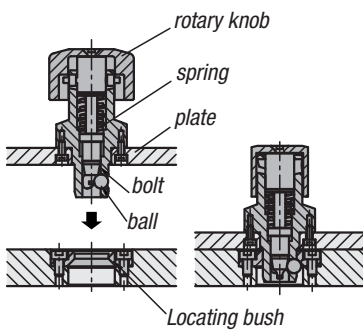

Repeat accuracy:

A higher repeat accuracy can be achieved with the aid of additional locating pins (not supplied).

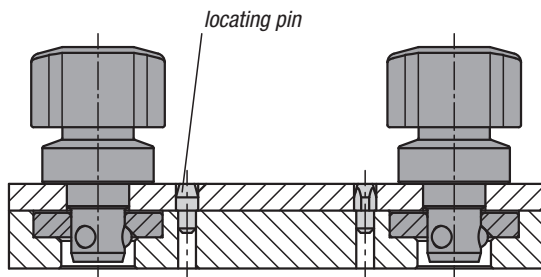

Production tolerances:

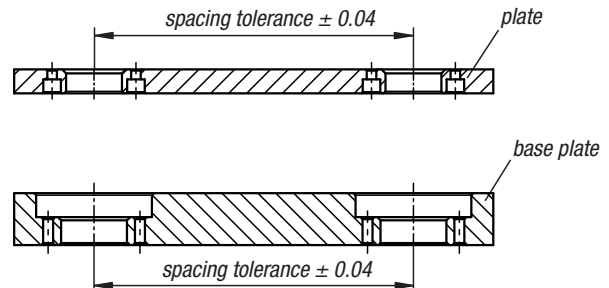

Application examples:



Change the machining fixture

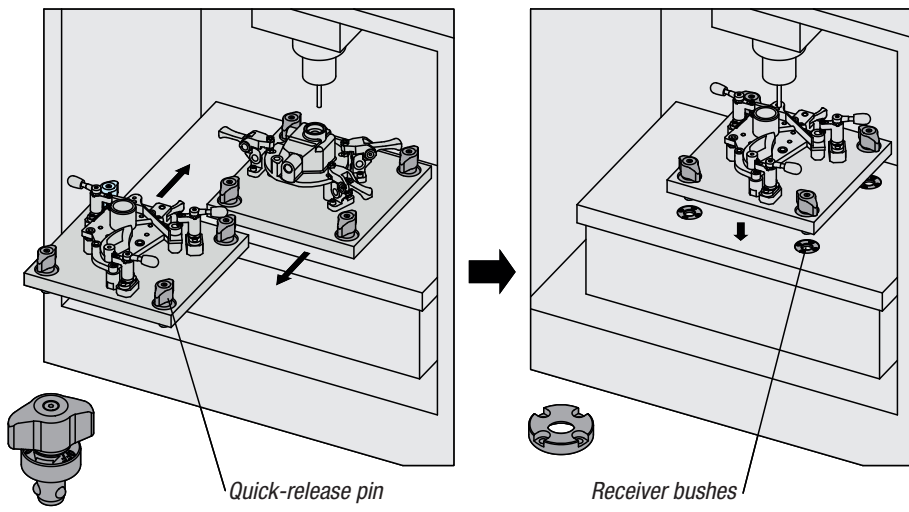

Change the welding fixture

