

# Collets

## for external clamping

### 1. Mounting collet:

- Insert an O-ring into the groove on the top face of the clamp base.
- Set a collet on the base making sure the locating pins fit into the locating holes on the underside of the collet. Secure the collet using a buttonhead hex socket screw.

#### Note:

Before mounting the collet, ensure the cam cylinder is fully loosened by turning the tightening screw clockwise until it stops.

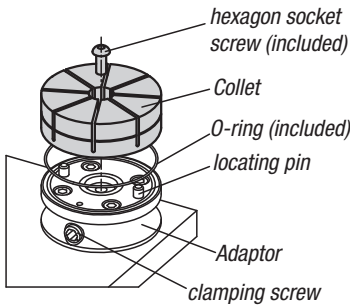

### 2.2

- Tighten the cam cylinder to clamp the clamp ring (recommended torque: 15Nm).
- Remove the screw from the clamp ring before machining.

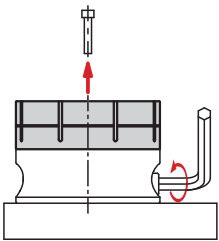

### 3. Mounting the workpiece:

- Loosen the cam cylinder and remove the clamp ring.
- Place the workpiece in the contour and re-tighten the cam cylinder.

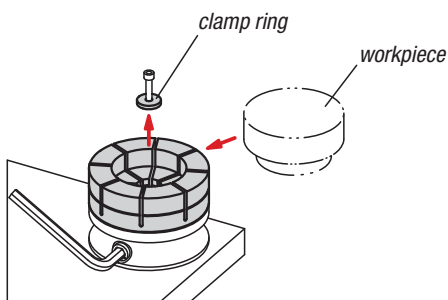

### 2. Machining collet:

#### 2.1

- Place the clamp ring in the centre of the collet. (Use a screw as an insertion aid)

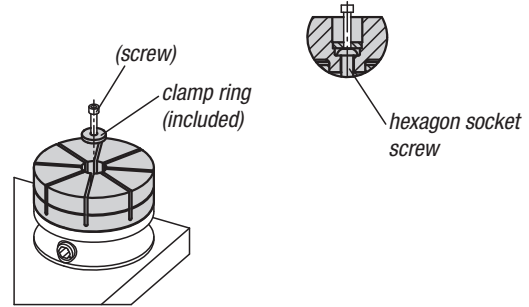

#### 2.3

- Machine the contour of the part that is to be held into the collet.

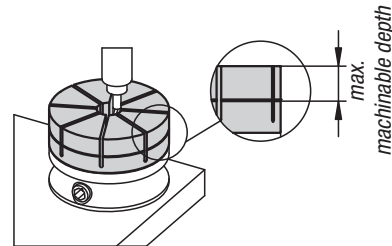

#### Note:

- Do not machine the contour deeper than the permitted depth.

### Performance curve

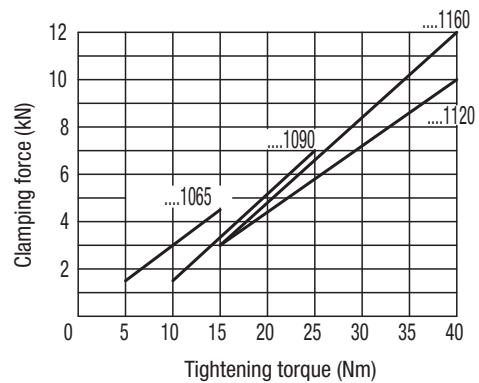

To avoid damaging the collet do not tighten the clamp without a workpiece or clamp ring.

Observe the maximum tightening torque in the table.