

5 Axis Clamping System

Trend-setting clamping concept for 5-sided machining

The 5-Axis Clamping System is an unbeatable overall concept to supplement state-of-the-art milling centres.

Many products are becoming more complicated than ever, and also have to be produced in an extremely short time and with maximum precision. In order to satisfy these criteria, the complete machining of workpieces is becoming increasingly more common. For this reason, state-of-the-art manufacturing technologies at machine tool manufacturers have developed toward 5-axis machining. Complete machining of workpieces on 5-axis centres transfers the entire high machine precision to the workpiece.

Due to the greater freedom for designing workpieces provided by 5-axis machining, a high-performance clamping system is an essential precondition for the efficient use of these machines.

Among other things, an optimised clamping system helps guarantee that the machine's complex travel can produce a high-precision workpiece.

The 5-axis clamping systems allow machining free of interfering edges and vibration, with extremely high cutting and feed forces. They enable the application of extremely short tools in order to guarantee the required tolerances and surfaces.



5 Axis Clamping System for trouble-free 5-sided machining in a single clamping

- Can be set up on grid hole plates, on T-slot plates and on your own fixtures
- Clamping force up to 42 kN by installing a tension spindle immediately under the workpiece
- Clamping width 22 - 236 mm, can be extended as desired using extension shafts
- Clamps rough pieces, round and irregular parts
- Positive-fit clamping without pre-embossing
- Various clamping heights (see illustration)
- Low clamping depth of 8 mm

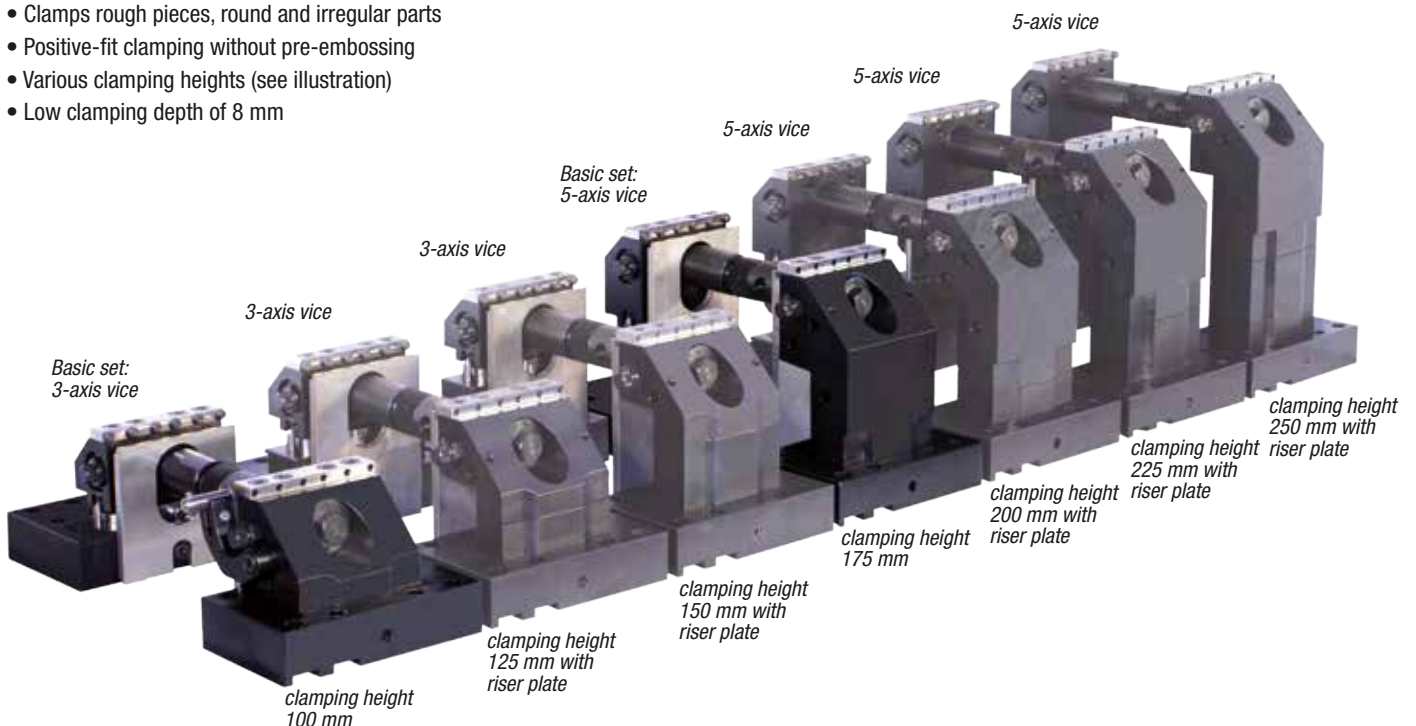

5 Axis Clamping System

Special technical features - clamping process



before clamping

The clamping process involves the penetration of hardened, exchangeable clamping pins in to the workpiece. This guarantees positive-fit clamping without pre-embossing. Optionally, flattened clamping pins are available for clamping workpieces with sensitive surfaces. Additional flexible applications are possible using accessories, including clamping jaws for specific clamping tasks and round clamping elements for clamping round parts.

The 5 axis clamping systems provides you with a universal clamping element that is able to clamp workpieces with a clamping width of 22 - 236 mm. The clamping width can be extended as desired through the use of extension shafts.



after clamping

High clamping forces up to 42 kN that are not lost due to flexing

By installing a tension spindle directly under the workpiece support the clamping force is generated where it is required.

- no widening the jaws under load
- no distortion of the machine table
- extreme rigidity allows highest cutting forces

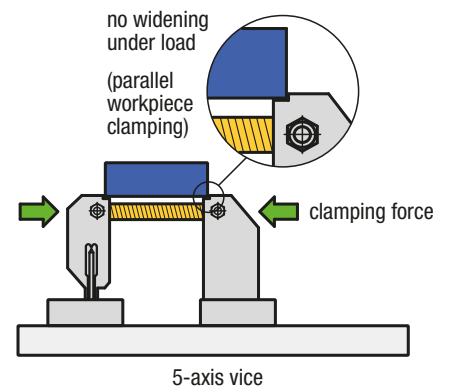
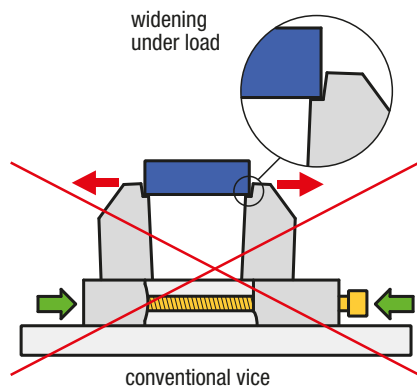

5-axis vice - system design

pos.	description	pcs.
1	fixed jaws	1
2	moveable jaws	1
3	base plate for fixed jaws	1
4	base plate for movable jaws	1
5	standard jaw pads with cap screws (5.1)	2
6	clamping pin	12
7	threaded spindle (7) with tension housing (7.1)	1
8	spindle nut	1
9	extension shaft (9) with union nut (9.1)	1
10	fastening screw	4
11	seating ledge	2
12	DIN 6912 M8x12 cap screw	2
13	pointer	1
14	DIN 913 M8x8 grub screw	1
15	DIN 912 M12x20 cap screw	2
16	DIN 912 M12x40 cap screw	3
17	DIN EN ISO 8735 8x20 dowel pin	2

