

## Workpiece stops for multi-clamping system

### Item description/product images



### Description

**Material:**  
Carbon steel.

**Version:**  
Tempered and flat faces ground (HRC 32).

**Note:**  
Workpieces can be positioned laterally using the workpiece stops for multi-clamping systems.

**Application:**  
The end stop can be mounted laterally on both surfaces of the fixed jaws.

**Advantages:**  
Flexible adjustment with the elongated hole.

### Drawings

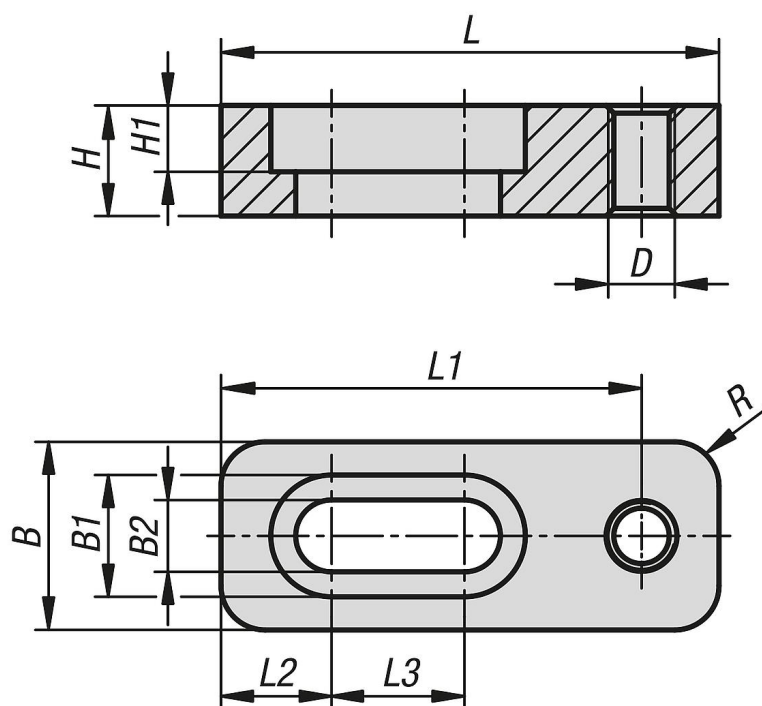

### Overview of items

#### Workpiece stops for multi-clamping system

Order No.	suitable for system width	L	B	H	L1	L2	L3	B1	B2	H1	R	D Internal thread
K1755.05045	50	45	17	10	38	10	12	11	6,5	6	4	M6
K1755.07250	72	50	17	10	43	10	12	11	6,5	6	4	M6
K1755.10055	100	55	25	15	45	11,5	16	14	9	8,5	5	M8

