

Selection guide for hydraulic swing clamps:

1. Piston diameter:

Example:

..... **25**101205190111

3. Mode of operation selection:

Example:

..... **25101205190111**

1 = double-acting

2 = single-acting with spring return

2. Travel:

Example:

..... **25101205190111**

4. Selection of oil supply connection type:

Example:

..... **25101205190111**

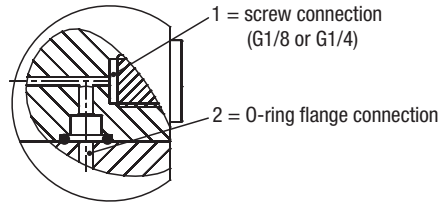

3 = Pressurised oil supply through drilled ducts

4 = Combination of screw connection/O-ring flange connection

Please note:

The mounting contour of the respective swing clamps.

5. Selection of the housing design:

Example:

..... **25101205190111**

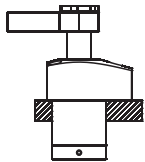

04 = Flange on top

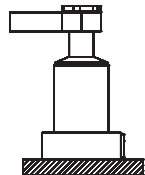

05 = Flange under

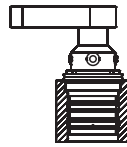

06 = Screw-on thread with drilled channels

6. Selection of seal type:

Example:

..... **25101205190111**

1 = NBR seal

7. Selection of swivel angle:

Example:

..... **25101205190111**

90 = 90°

8. Selection of swivel direction:

Example:

..... **25101205190111**

1 = Right swivel

2 = Left swivel

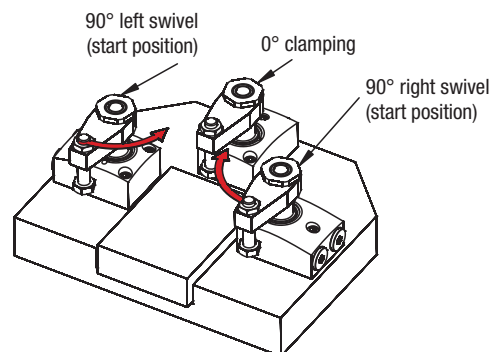
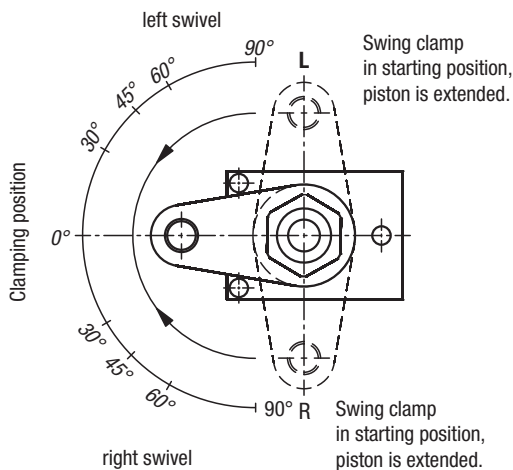

Selection guide for hydraulic swing clamps:

9. Selection of overload protection:

Example:

..... 25101205190111

1 = Overload protection

10. Selection of metal wiper:

Example:

..... 25101205190111

1 = Metal wiper

11. Selection of clamping arm for swing clamp:

- Swing clamps are supplied with a taper mount with fastening nut.
- Clamping arms for swing clamps must be ordered separately.

Form A

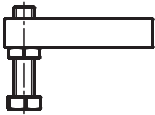

Form B



Form C



Form D



clamping force diagram

Max. clamping arm length L_1 must be observed.

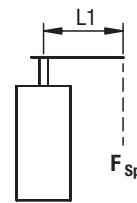
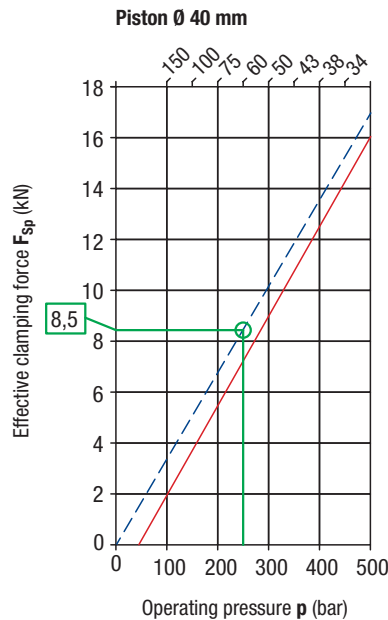
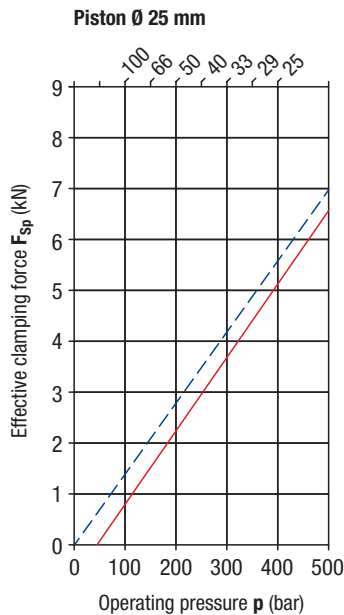

- - - double-acting
- - - single-acting

Example:

- double-acting cylinder, piston Ø 40 mm
- available operating pressure $p = 250$ bar
- Form A clamping arm length $L_1 = 60$ mm
- resulting clamping force $F_{Sp} \sim 8.5$ kN

The counteracting spring return force by the single-acting swivel clamps reduces the clamping force slightly. To achieve the same clamping force as with the double-acting swing clamps, the operating pressure must be increased slightly.

Mounting and application examples:

Form A:

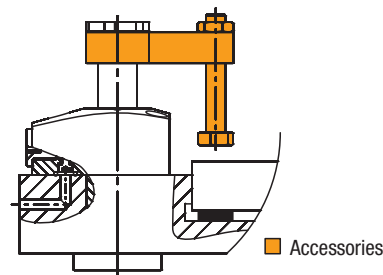
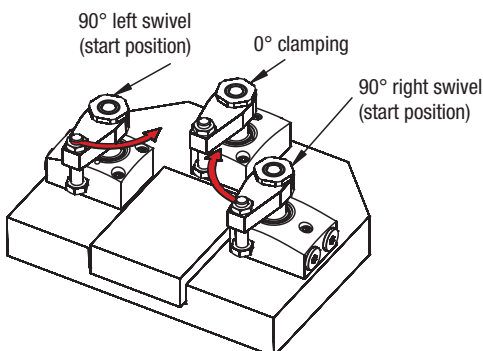

A pipe thread connection or O-ring flange connection can be used depending on the application.

Mounting and application examples:

Form B:

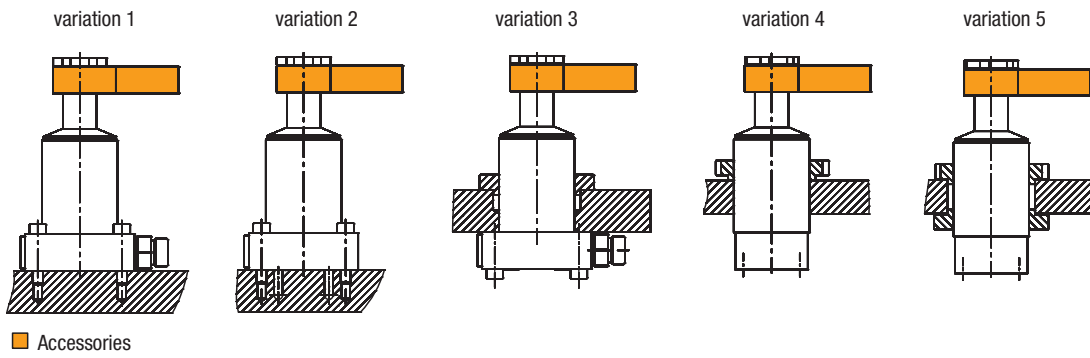
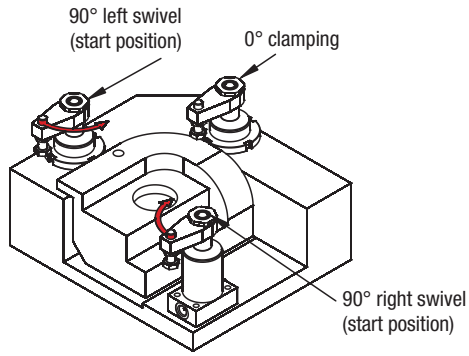

Form C:

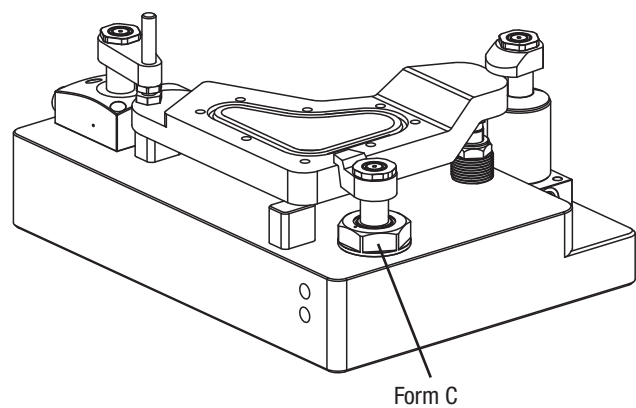
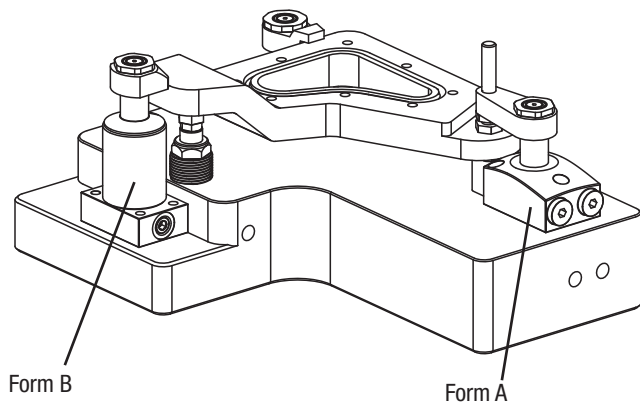
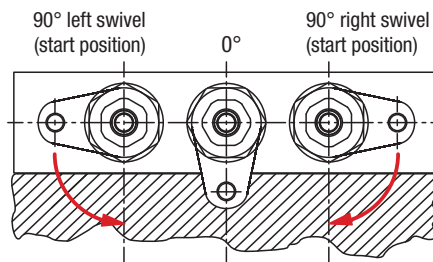
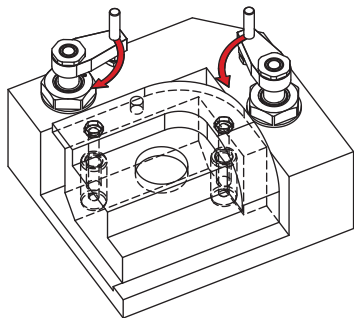

Mounting/Removing the clamping arm:

When mounting or removing the clamping arms, make sure that no torques are transmitted to the piston rod of the swing clamp. This can be prevented by holding the arm in place when tightening or loosening the fastening screw.

1. If the swing clamp is equipped with an overload protection, the first step is to check it by turning the piston until the overload protection can be felt to engage. A swing clamp has three engagement points at 120° intervals.
2. The installation of the clamping arms is normally carried out when the clamp is not under pressure. After the clamping arm is positioned on the piston rod, the screw or nut can be tightened. However, if an exact clamping position of the clamping arm is required, the piston of the swing clamp must be retracted under pressure. The clamping arm can then be mounted in the desired position.
3. After attaching the clamping arm, the clamping process of the swing clamp should be checked several times for correct clamping point and clamping travel.
4. After changing the clamping arm, the torque of the fastening screw should be checked again after a few clamping cycles and, if necessary, retightened.

Connection dimensions for in-house production of clamping arms:

Tapered mount

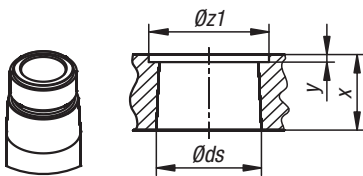

| | | | |
|----------------------|------|------|------|
| Piston \varnothing | (mm) | 25 | 40 |
| $\varnothing ds$ | (mm) | 20 | 32 |
| $\varnothing z1$ | (mm) | 24 | 34 |
| x | (mm) | 16 | 23 |
| y | (mm) | 4 | 5 |
| Taper ratio | | 1:10 | 1:10 |

Attention: Observe protruding edges of the housing.