

Toe clamps compact

Item description/product images

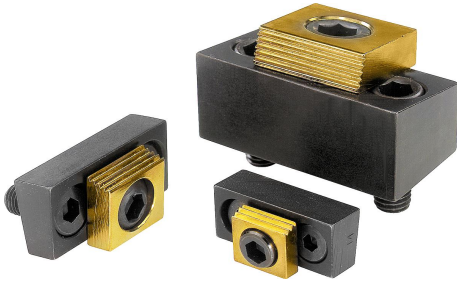

Example of series clamping using compact toe clamps

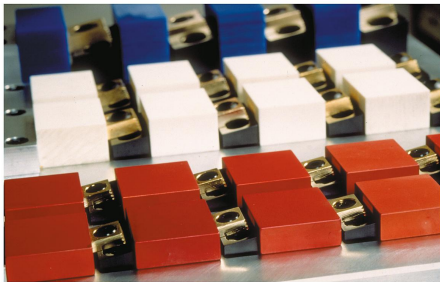

Description

Material:
Steel.

Version:
Body tempered and black oxidised.
Square washer case-hardened and brass-plated.

Note:

This cam action compact toe clamp requires very little space to produce multi-fixture clamping.

Workpieces can be clamped in series by using the back side of a clamp as a stop for the next row.

Mount preferably in slots with $B +0.05$ mm. The height of the clamp can be adjusted by altering the slot depth.

Drawings

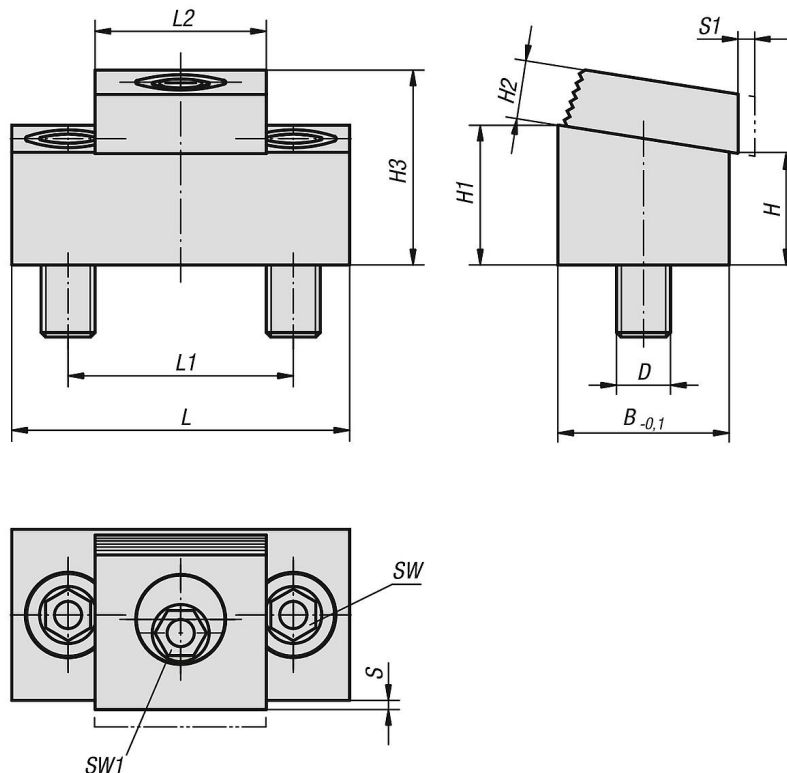

Overview of items

Toe clamps compact

Toe clamps compact

Overview of items

Order No.	L	L1	L2	B	H	H1	H2	H3 max.	S	D	S1 (travel)	SW	SW1	Clamping force kN	Tightening torque max. Nm	Accessories KIPP
K0036.08	43,2	25,4	19	19	12,7	15,7	6,4	21,4	1,5	M8	1,6	5	7	8,9	28	K1969.1013
K0036.10	54	33,5	25,4	25,4	11,4	15,4	9,7	24,5	1,8	M10	2	7	8	17,8	88	K1969.1216
K0036.12	75	50,8	38	38,1	25,5	31,5	13	43	2,05	M12	2,5	10	12	26,7	135	K1969.1630